

This test covers magnetic fields, magnetic forces on charged particles and current-carrying wires, the Hall effect, the Biot-Savart Law, Ampère's Law, and the magnetic fields of current-carrying loops and solenoids, with some problems requiring knowledge of basic calculus.

Part I. Multiple Choice

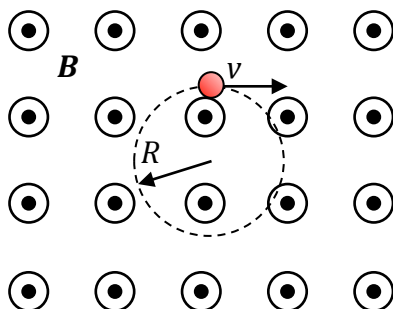

1. A charged particle of mass m is exposed to a constant magnetic field of magnitude B and directed out of the page, in which the particle moves in a clockwise circle of radius R with a speed v , as shown. In a separate experiment, the same particle is traveling with a speed $2v$ in a constant magnetic field of the same magnitude B , now directed *into* the page. Which of the following statements is true?
 - a. Now the particle travels in a clockwise circle of radius R .
 - b. Now the particle travels in a counterclockwise circle of radius R .
 - c. Now the particle travels in a counterclockwise circle of radius $2R$.
 - d. Now the particle travels in a clockwise circle of radius $R/2$.
 - e. Now the particle travels in a counterclockwise circle of radius $R/2$.

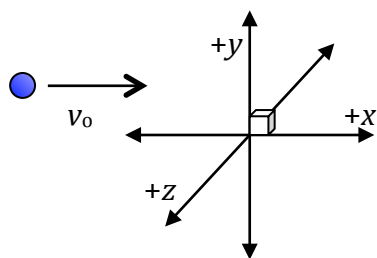

2. An electron with an initial velocity v_0 in the x direction enters a region of space containing an electric field \mathbf{E} and a magnetic field \mathbf{B} , both individually oriented along the x -, y -, or z -axes. Once in this region of space, the particle begins to move in a counter-clockwise circle in the x - y plane, with an increasing velocity component in the positive- z direction. What are the orientations of the \mathbf{E} and \mathbf{B} fields?

	\mathbf{E}	\mathbf{B}
a.	$-z$	$+z$
b.	$+z$	$+z$
c.	$-z$	$-z$
d.	$+z$	$-z$
e.	$-z$	$+x$

3. A charged particle moves through a region of space at constant speed, without deflecting. From this, one can conclude that in this region:
- There must be no magnetic field.
 - There must be no magnetic field and no electric field.
 - There could be electric and magnetic fields, oriented in the same direction.
 - There could be electric and magnetic fields, oriented in opposite directions.
 - There could be electric and magnetic fields, oriented perpendicular to each other.

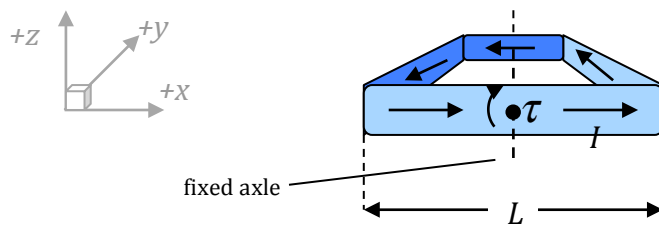

4. A square loop of wire, with sides of length L , is oriented in the x - y plane, and able to rotate about an axle along the y -axis and running through the middle of the loop, as shown. The loop carries a current I in the direction indicated, and a constant magnetic field B is applied so as to create a torque τ in the clockwise direction. What is the maximum magnitude of this torque?
- $\tau = IL^2B$
 - $\tau = \frac{1}{2}IL^2B$
 - $\tau = 2IL^2B$
 - $\tau = 4IL^2B$
 - $\tau = 4ILB$

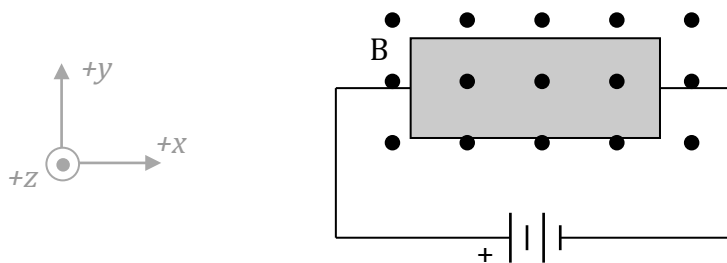

5. A conductor lying in the xy plane is exposed to a magnetic field in the $+z$ direction, and connected to a source of potential as shown above. Which statement correctly describes the electric field within the conductor?
- There is only an E field in the $+x$ direction
 - There is only an E field in the $-x$ direction
 - There are E field components in the $+x$ direction and the $+y$ direction
 - There are E field components in the $-x$ direction and the $+y$ direction
 - There are E field components in the $+x$ direction and the $-y$ direction

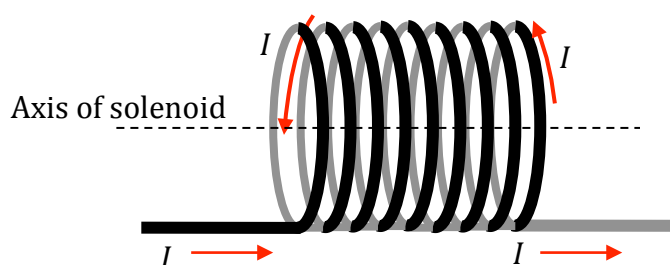

6. An ideal solenoid has a current I flowing through it, up in front and down in back, as shown above. Which of the following statements is true?
- The magnetic field inside the solenoid points to the right.
 - The magnetic field strength is greater outside the solenoid than inside the solenoid.
 - The magnetic field inside the solenoid is proportional to I .
 - The magnetic field inside the solenoid is proportional to its radius.
 - The magnetic field inside the solenoid is inversely proportional to its radius.

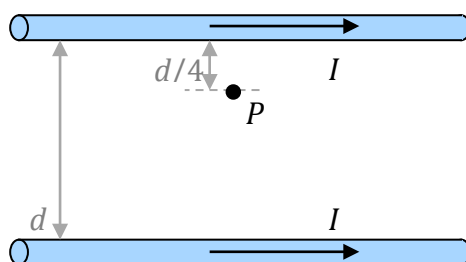

7. Two long, thin, parallel wires are separated by a distance d and each carry a current I to the right as shown above. What is the net magnetic field due to these two wires at a point P , located at a distance $d/4$ from the upper wire?
- $\frac{8\mu_0 I}{3\pi d}$, into the page
 - $\frac{4\mu_0 I}{3\pi d}$, into the page
 - 0
 - $\frac{8\mu_0 I}{3\pi d}$, out of the page
 - $\frac{4\mu_0 I}{3\pi d}$, out of the page

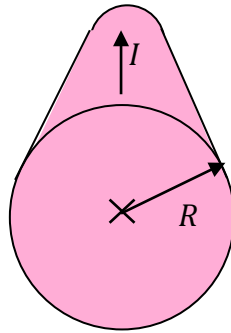

8. A solid wire of has a radius R and carries a current I into the page as shown. The magnitude of the magnetic field due to I varies as a function of r . Which graph best represents this relationship?

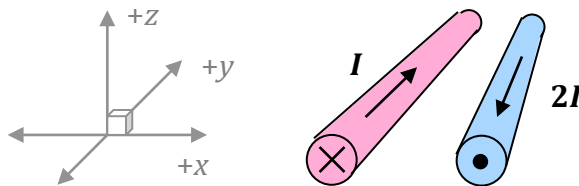
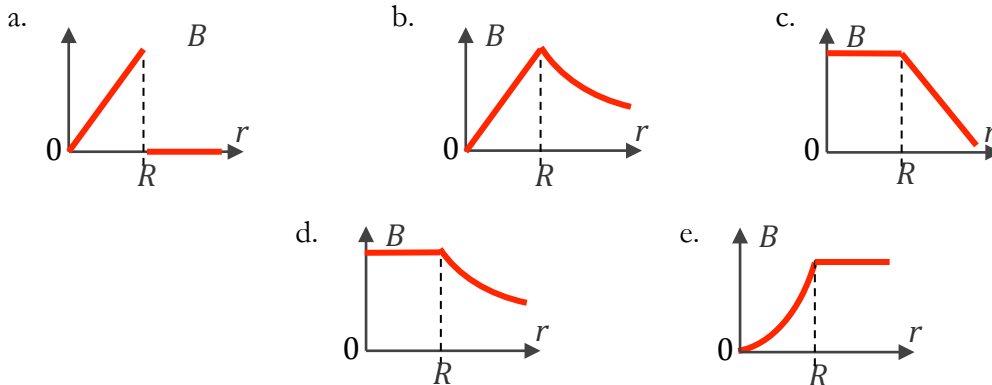

9. Two long parallel wires, oriented along the y -axis as shown, contain currents I and $2I$, flowing in opposite directions. Which of the following statements is true?

- The magnetic field due to I circles that wire in a counterclockwise direction.
- The magnetic force from wire $2I$ on wire I is twice as strong as the force on wire I from wire $2I$.
- The magnetic force between the two wires is proportional to the inverse square of the distance between them.
- The force on wire $2I$ is in the $+x$ direction.
- The force on wire $2I$ is in the $-z$ direction.

Part II. Free Response

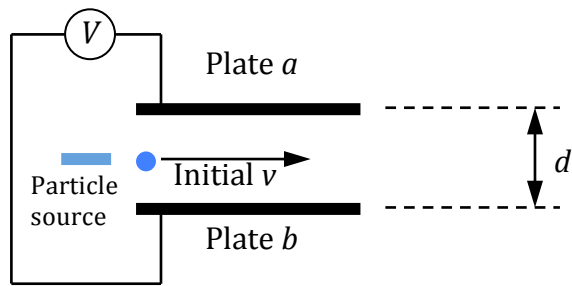

- In the diagram above, a potential difference V is set up between plates a and b so that charged particles, emitted from the particle source with various unknown initial velocities v , are exposed to a constant electric field between the plates. The plates are separated by a distance d , and particles from the source have a mass m and a positive charge q . Give answers in terms of given variables and fundamental constants.
 - Calculate the magnitude of the electric field between the plates.
 - Calculate the magnitude of the acceleration of a particle as it travels through the distance between the plates?
 - If the particles from the source have a *positive* charge, which plate, a or b , should be at high potential to cause the particle to accelerate towards plate a ? Briefly explain your reasoning.

The charged particles accelerate toward plate a , but now a constant magnetic field is established in the same region between the plates, in a direction perpendicular to the electric field.

- d. Which direction should the magnetic field be oriented to counteract the electric force acting on the positively charged particles?

- e. Calculate the magnitude the magnetic field should have so that a particle with a desired velocity v will continue to travel in a straight line through the region between the plates.

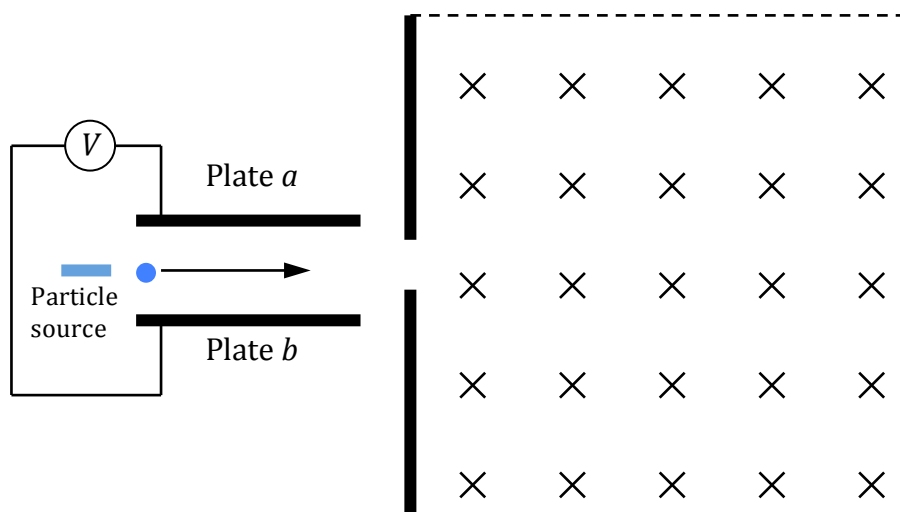

The particle with velocity v now leaves the region between the plates and moves into an area where a uniform magnetic field of magnitude B' is oriented as shown above.

- f. On the diagram above, sketch the path of the positively charged particle as it travels through this region of space.

- g. Calculate the radius of curvature for the path of the positively charged particle.

2. A student uses a 10.0-meter long length of copper wire (resistivity $1.68 \times 10^{-8} \Omega \cdot m$, diameter $1.00 \times 10^{-3} m$) to create a solenoid that is 3.00 centimeters in radius.
- Calculate the resistance of the total length of wire.
 - Calculate how many turns of wire there are in this solenoid.
 - Assuming the turns of wire are placed directly adjacent to each other, determine the length of the solenoid.
- A 3.00 Volt potential difference is applied across the wires of the solenoid.
- Calculate the current that passes through the solenoid.

- e. Calculate the magnitude of the magnetic field inside the solenoid.
- f. Calculate the magnetic flux through the cross-sectional area in the middle of the solenoid.

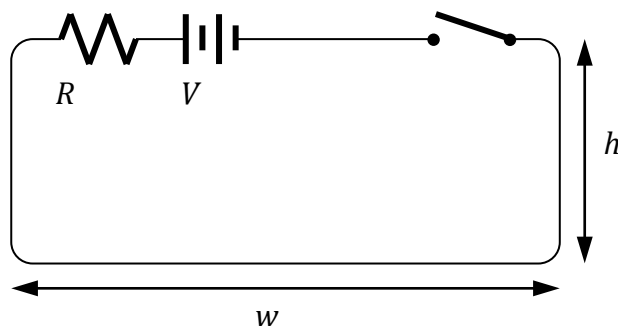

3. A simple current-carrying circuit is created consisting of a length of wire, a switch, a resistor R , and a battery with terminal voltage V , as shown. The circuit has a width w and a height h . Answers should be given in terms of the indicated variables and fundamental constants.
- a. A long time after the switch is closed, what is the magnitude and direction of the current in the circuit?

The switch is opened and the loop is suspended from a vertical spring scale, with the spring scale indicating an initial weight of W for the loop. Then, a constant magnetic field is applied to the lower half of the circuit as shown, and the circuit switch is again closed.

- b. The weight indicated by the scale, W' , is now

greater than W _____
 equal to W _____
 less than W _____

Briefly explain your reasoning.

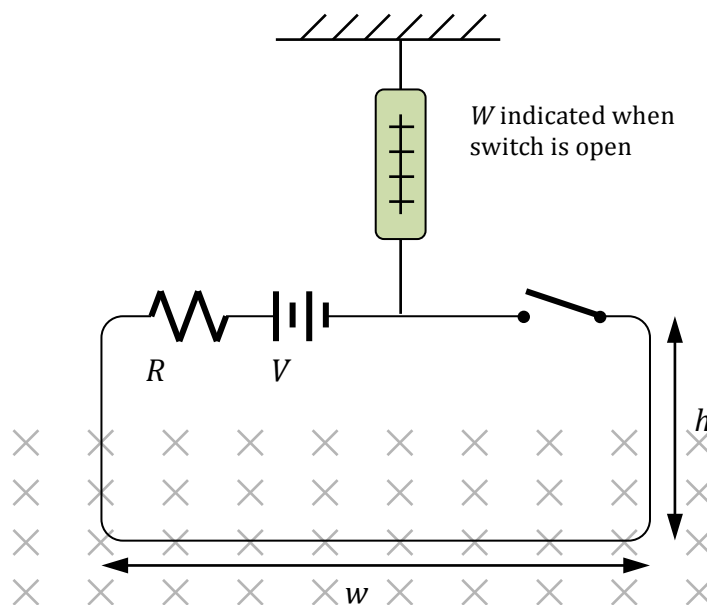

- c. Based on this experimental set-up and the new weight W' , calculate the magnitude of the magnetic field B .
- d. In an independent measurement of the magnetic field, it is determined that the magnetic field strength is actually less than the value of B calculated above. Indicate two realistic reasons for this discrepancy.

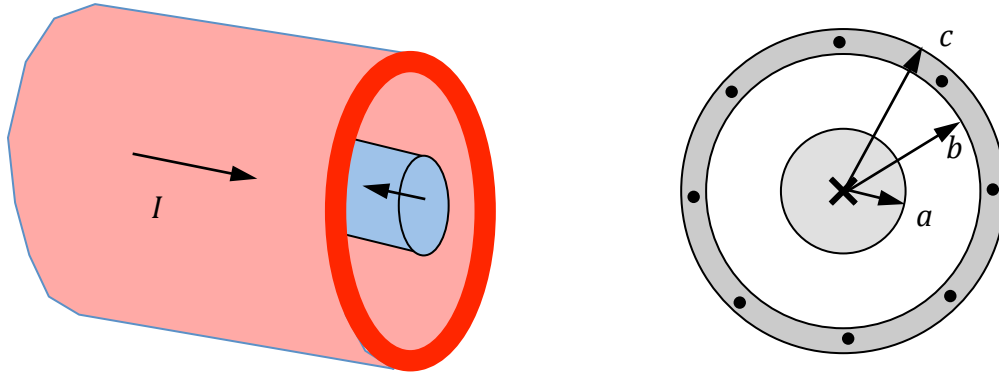

4. A coaxial cable consists of two conductors, a solid inner conductor of radius a , and an outer conductor of inner radius b and outer radius c . The inner cable carries a constant density current I into the page and the outer conductor carries an identical current I , also of constant density, out of the page.
- Use Ampère's Law to calculate the magnetic field magnitude and direction at
 - $r < a$

ii. $a < r < b$

iii. $b < r < c$

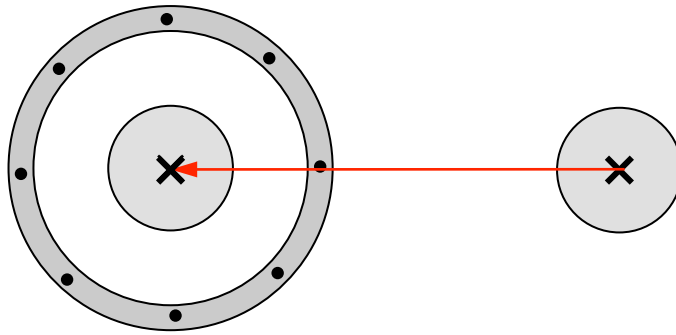

- b. A second conductor, a single wire also carrying a current I into the page, is now placed parallel to the co-axial cable at a distance $r > c$.
- Calculate the magnetic field magnitude and direction due to this new conductor at the location of the coaxial cable's center.
 - Calculate the magnitude and direction of the force-per-unit-length on the coaxial cable due to this new conductor's magnetic field.

Part I. Multiple Choice

1. The correct answer is *c*. The different direction for the magnetic field in the second experiment results in a counterclockwise path, according to the Right Hand Rule. There will be a greater magnetic force on the particle, according to $\mathbf{F}_B = q\mathbf{v} \times \mathbf{B}$, but the greater velocity of the particle results in a greater radius for its circular motion. Mathematically:

$$\mathbf{F}_B = q\mathbf{v} \times \mathbf{B}$$

$$F_c = \frac{mv^2}{r}$$

$$F_c = F_B$$

$$\frac{mv^2}{r} = qv \times B$$

$$r = \frac{mv}{qB}$$

With a velocity of $2v$ for the second experiment, the radius R will be twice as large.

2. The correct answer is *a*. The counter-clockwise circular motion in the x - y plane suggest that there is a magnetic force initially in the $+y$ direction. For a negatively-charged particle like an electron, the Right-Hand Rule indicates that this motion would be associated with a magnetic field out of the page, in the positive- z direction. And the increasing velocity component in the positive- z direction would indicate—again, for a *negative* charge—an electric field in the opposite, or negative- z , direction.
3. The correct answer is *e*. A magnetic field in this region of space will cause the charged particle to accelerate in a direction perpendicular to its motion. To counter this acceleration, an electric field must be placed in the same area. However, electric fields cause acceleration along the same axis as the field—thus, this electric field must be perpendicular to the magnetic field. Once such orientation (for a positively-charged particle) is shown here:

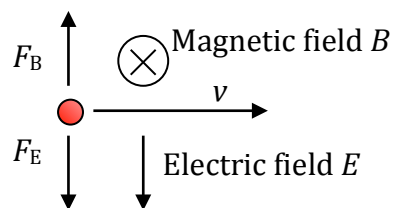

4. The correct answer is *a*. The magnetic field will need to be applied to the right, as determined by applying the Right Hand Rule to the currents in the segments of wire oriented along the y -axis. The magnitude of that torque is determined as follows:

$$\boldsymbol{\tau} = \mathbf{r} \times \mathbf{F}$$

$$\boldsymbol{\tau} = \frac{1}{2}L \times ILB$$

$$\boldsymbol{\tau} = 2\left(\frac{1}{2}IL^2B\right)\sin\theta$$

$$\boldsymbol{\tau}_{\max} = IL^2B$$

where we have multiplied the torque effect by 2 for the two wires of length L .

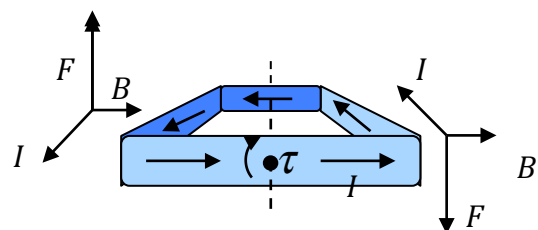

5. The correct answer is *e*. There is an electric field in the $+x$ direction due to the potential set up by the source of potential—it is this field that is responsible for moving charges through the circuit. By virtue of the magnetic field, there is a magnetic force on the moving charges that pushes electrons down (in the $-y$ direction), leaving net positive charge on the upper border of the conductor. This *Hall Effect* continues until the magnetic force on the particles ($F = qv \times B$) is equal in magnitude to the electric force ($F = qE$) due to the electric field resulting from the potential difference top-to-bottom in the body of the conductor. In this case, the direction of that electric field is from top-to-bottom, or in the $-y$ direction.

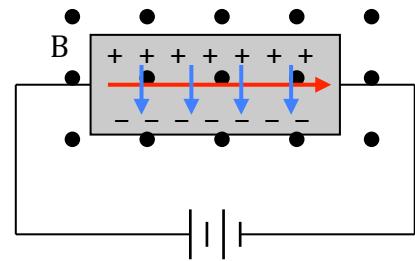

6. The correct answer is *c*. The magnetic field for a solenoid can be derived by applying Ampère's Law to a section of the coil as shown here, with a path of length ℓ and height h . Although the entire length of the path is $2\ell + 2h$, the path segment outside the solenoid has negligible magnetic field, and the vertical path segments between the coils have net $B=0$ due to opposite field directions from adjacent coils. Thus, the only magnetic field is inside the solenoid, and determined as follows:

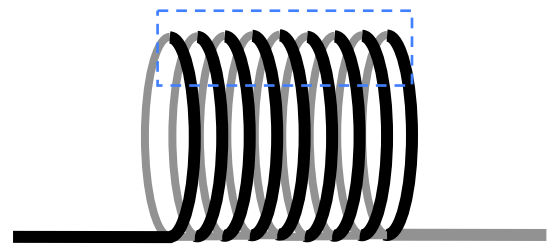

$$\oint \mathbf{B} \cdot d\mathbf{s} = \mu_0 NI$$

$$B(\ell) = \mu_0 NI$$

$$B_{\text{solenoid}} = \frac{\mu_0 NI}{\ell} = \mu_0 nI$$

7. The correct answer is *b*. The magnetic field due a a long, current-carrying wire is given by

$$B = \frac{\mu_0 I}{2\pi r}$$

We can determine the net magnetic field at point *P*, then, as follows:

$$B_{\text{upper}} = \frac{-\mu_0 I}{2\pi(d/4)}, \text{ where negative sign indicates "into the page"}$$

$$B_{\text{lower}} = \frac{+\mu_0 I}{2\pi(3d/4)} \text{ (out of the page)}$$

$$B_{\text{net}} = \frac{-\mu_0 I}{2\pi(d/4)} + \frac{+\mu_0 I}{2\pi(3d/4)} = \frac{-4\mu_0 I}{3\pi d} \text{ (into the page)}$$

8. The correct answer is *b*. By considering Ampère's Law— $\oint \mathbf{B} \cdot d\mathbf{s} = \mu_0 I$ —we can determine the magnetic field at various distances from the center of the wire. Inside the wire, we see that the field increases linearly with radius r :

$$\oint \mathbf{B} \cdot d\mathbf{s} = \mu_0 I$$

$$B_{in}(2\pi r) = \mu_0 I_{in}, \text{ where } I_{in} = \frac{\pi r^2}{\pi R^2} I_0$$

$$B_{in} = \frac{\pi r^2}{(2\pi r)\pi R^2} \mu_0 I_0 = \frac{\mu_0 I_0 r}{2\pi R^2}$$

Outside the wire, the magnetic field diminishes as the inverse of r .

$$\oint \mathbf{B} \cdot d\mathbf{s} = \mu_0 I$$

$$B(2\pi r) = \mu_0 I$$

$$B = \frac{\mu_0 I_0}{2\pi r}$$

9. The correct answer is d . The magnetic field due to wire I circles that wire in a clockwise direction, as determined using the Right Hand Rule. This field is down (in the $-z$ direction) at the location of wire $2I$. By applying another Right Hand Rule, we can determine that the magnetic force on $2I$ due to this magnetic field is in the $+x$ direction.

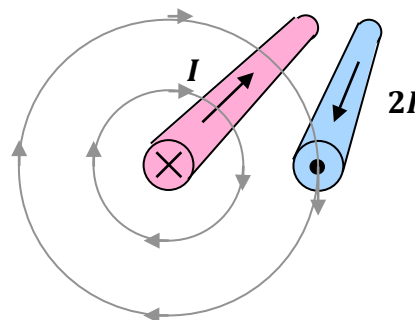

Wire $2I$ has a force equal in magnitude on wire I . The magnetic force between the two wires can be determined as follows:

Magnitude of magnetic field due to I :

$$B = \frac{\mu_0 I}{2\pi r}, \text{ where } r \text{ is the distance between the wires}$$

Force on wire $2I$ due to this field:

$$F_B = I\ell \times B$$

$$F_B = (2I)\ell \times \frac{\mu_0 I}{2\pi r}$$

The force per unit length of the wires, then, is:

$$\frac{F_B}{\ell} = \frac{\mu_0 2I^2}{2\pi r}$$

Part II. Free Response

1.

- a. The magnitude of the electric field between the plates is

$$E = -\frac{dV}{dr} = \frac{V}{d}$$

- b. The acceleration of a particle as it travels between the plates is calculated as follows

$$F_{net} = ma$$

$$F_{electric} = qE$$

$$qE = ma$$

$$a = \frac{qE}{m} = \frac{qV}{md}$$

- c. For a positive charge to accelerate toward a , the electric field needs to be pointing towards a . Electric fields point away from high potential and towards low potential, so plate b should be at a high potential.
- d. We need the magnetic force F_B to be toward plate b (down), so by the Right-Hand Rule, the magnetic field should be oriented out of the page (towards us).

- e. To travel straight through the plates, the electric force and magnetic force need to equal each other. So:

$$F_{net} = F_B + F_e = ma = 0$$

$$-qv \times B + qE = 0$$

$$B = \frac{E}{v} = \frac{V}{vd}$$

- f. The particle should trace a path that is an arc of constant radius and bending up, or to the left relative to the particles direction of motion. The arc should begin turning as soon as the particle enters the field, and should clearly be circular in form, not elliptical.
- g. The radius of curvature is based on considering the magnetic force F_B as a centripetal force:

$$F_B = F_{centripetal}$$

$$qv \times B = m \frac{v^2}{r}$$

$$r = \frac{mv^2}{qvB'} = \frac{mv}{qB'}$$

2.

- a. To calculate the resistance of the wire, based on its length, resistivity, and cross-sectional area:

$$R = \rho \frac{L}{A} = \rho \frac{L}{\pi r^2}$$

$$R = (1.68e-8 \Omega \cdot m) \frac{10.0m}{\pi(0.50e-3m)^2} = 0.214 \Omega$$

- b. There are 10.0 meters of wire, and each turn (loop) of wire has a circumference

$$C = 2\pi r = 2\pi(0.03m) = 0.1885m$$

$$\text{Therefore, there must be } \frac{10.0m}{1} \times \frac{1 \text{ turn}}{0.1885} = 53.1 \text{ turns}$$

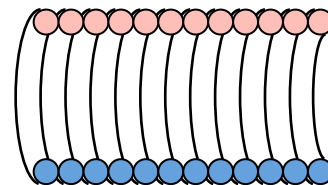

Cross-section view of
solenoid turns

- c. Each turn is the width of the wire, $1.00 \times 10^{-3} m$, so

$$\frac{53.1 \text{ turns}}{1} \times \frac{1.00e-3m}{1 \text{ turn}} = 5.31 \times 10^{-2} \text{ meters} = 0.0531m = 5.31cm$$

- d. Based on the 3.00 Volt terminal voltage:

$$I = \frac{V}{R} = \frac{3V}{0.214 \Omega} = 14.0A$$

- e. The magnetic field inside the solenoid has a magnitude

$$B = \mu_0 n I = \frac{\mu_0 N I}{\ell}$$

$$B = \frac{(4\pi \times 10^{-7})(53.1)(14.0A)}{(0.0531m)} = 1.76 \times 10^{-2} \text{ Tesla}$$

- f. The magnetic field in a solenoid is relatively constant, but does start to weaken a little at either end of the solenoid. In the middle of the solenoid, we should have the full strength of the magnetic field in effect.

$$\Phi_B = \int B \cdot dA$$

$$\Phi_B = BA = B(\pi r^2)$$

$$\Phi_B = (1.76 \times 10^{-2} T)(\pi)(0.03m)^2 = 4.98 \times 10^{-5} T \cdot m^2$$

3.

- a. This problem specifies “a long time after the switch is closed” because we’re about to start considering inductance, which has an inhibiting effect on the immediate flow of charge. The effect is small here, however.

Using Ohm’s Law: $I = \frac{V}{R}$

- b. W' is less than W . The magnetic force $F_B = I\ell \times B$, by the Right-Hand Rule, produces an upward magnetic force which lessens the value indicated by the spring scale.
- c. The magnitude of B as a function of other variables given, is based on a static equilibrium analysis. You should absolutely begin with a free-body diagram!

$$F_{net} = 0$$

$$+F_B + W' - W = 0$$

$$I\ell B = W - W'$$

$$B = \frac{W - W'}{Iw} = \frac{R(W - W')}{Vw}$$

- d. If our measured B is too big there must be a problem with one of our measurements. Some possibilities:

- perhaps the resistance is higher than we thought: the resistor is heating up as current runs through it? The indicated resistance on the component was lower than its actual resistance?
- The voltage may be lower than we initially measured: the battery is running down? internal resistance has caused a decrease in the voltage?
- The width of the wire is actually somewhat less than w due to the rounded edges of the wire loop.

Problems with the calibration of the scale are not good reasons in this experiment, as any calibration error is negated by using a relative difference in the weights.

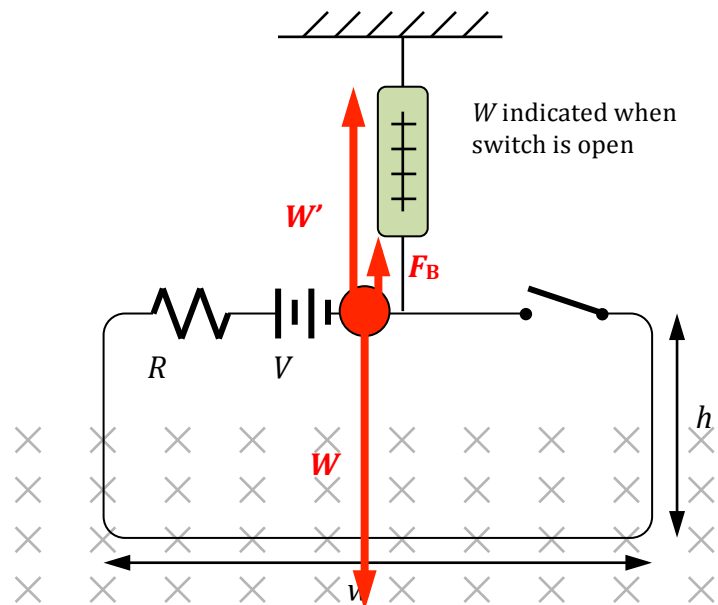

4.

a.

- i. Inside the inner conductor, the magnetic field is due only to the current enclosed by the Ampèrian path of radius r :

$$\oint \mathbf{B} \cdot d\mathbf{s} = \mu_0 I$$

Cross-sectional current density is constant, so

$$\sigma = \frac{I}{A} \rightarrow \frac{I_{total}}{\pi a^2} = \frac{I_{enclosed}}{\pi r^2} \rightarrow I_{enclosed} = \frac{\pi r^2}{\pi a^2} I_{total}$$

$$B(2\pi r) = \mu_0 \left(\frac{\pi r^2}{\pi a^2} I_{total} \right)$$

$$B = \frac{\mu_0 \pi r^2 I_{total}}{(2\pi r)\pi a^2} = \frac{\mu_0 r I}{2\pi a^2}, \text{ clockwise}$$

- ii. The magnetic field in the gap between the two coaxial conductors is just due to the internal current I :

$$\oint \mathbf{B} \cdot d\mathbf{s} = \mu_0 I$$

$$B = \frac{\mu_0 I}{2\pi r}, \text{ clockwise}$$

- iii. As we consider the current flowing in the exterior cylindrical shell, we have to consider the net current as $I_{internal}$ less a fraction of the current flowing in the opposite direction:

$$B(2\pi r) = \mu_0 (I_{inner} - I_{outer})$$

$$I_{inner} = I;$$

$$I_{outer} = \left(\frac{A_{outer-fraction}}{A_{outer-total}} \right) I$$

$$I_{outer} = \left(\frac{\pi r^2 - \pi b^2}{\pi c^2 - \pi b^2} \right) I = \left(\frac{r^2 - b^2}{c^2 - b^2} \right) I$$

$$B = \frac{\mu_0}{2\pi r} \left(I - \left(\frac{r^2 - b^2}{c^2 - b^2} \right) I \right)$$

$$B = \frac{\mu_0 I}{2\pi r} \left(1 - \frac{r^2 - b^2}{c^2 - b^2} \right), \text{ clockwise}$$

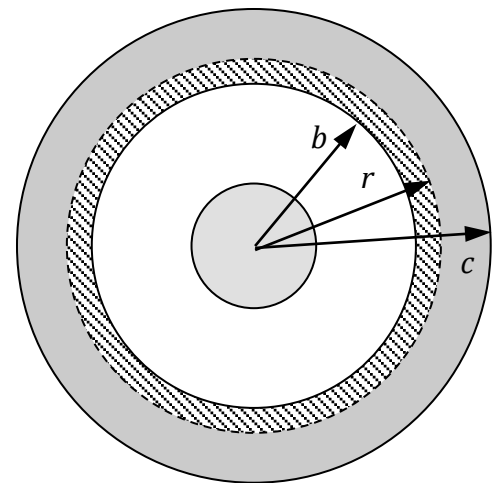
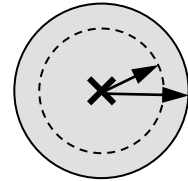

Hatched section shows fraction of current coming out of page.

b.

- i. Magnetic field due to a current-carrying wire is just:

$$B = \frac{\mu_0 I}{2\pi r}, \text{ up}$$

- ii. $\mathbf{F} = I\ell \times \mathbf{B}$, but there is no net current at the position of the coaxial cable, so the net Force is 0!